

Particle Engineering for Direct Compression via QESD Crystallization

Inaugural-Dissertation

zur Erlangen des Doktorgrades
der Mathematisch-Naturwissenschaftlichen Fakultät
der Heinrich-Heine-Universität Düsseldorf

vorgelegt von

Jerome Hansen

aus Iserlohn

Düsseldorf, Juni 2022

Aus dem Institut für Pharmazeutische Technologie und Biopharmazie
der Heinrich-Heine-Universität Düsseldorf

Gedruckt mit der Genehmigung der
Mathematisch-Naturwissenschaftlichen Fakultät der
Heinrich-Heine-Universität Düsseldorf

Referent: Prof. Dr. Dr. h.c. Peter Kleinebudde
Koreferent: Prof. Dr. Jörg Breitzkreutz

Tag der mündlichen Prüfung: 05.09.2022

Für meine Familie

“If I have seen further, it is by standing on the shoulders of giants.”

Sir Isaac Newton

Table of contents

List of publications and contributions	iii
Published manuscripts.....	iii
Congress presentations.....	iv
List of Abbreviations	v
1. Introduction	1
1.1 General.....	1
1.2 Crystallization	2
1.2.1 General	2
1.2.2 Crystal morphology.....	3
1.2.3 Polymorphs and solvates.....	4
1.2.4 Crystallizers.....	5
1.3 Spherical crystallization.....	10
1.3.1 General	10
1.3.2 Quasi-emulsion solvent-diffusion method	10
1.3.3 Spherical agglomeration	14
1.3.4 Ammonia-diffusion method	14
1.4 Tableting and direct compression	15
1.5 Prerequisites for direct compression	17
1.5.1 General	17
1.5.2 Flowability	17
1.5.3 Storage agglomeration	18
1.6 Problematic APIs for direct compression.....	19
1.6.1 General	19
1.6.2 Metformin hydrochloride	19
1.6.3 Celecoxib	20
References	22
2. Aim of the thesis	28
3. Results and Discussion	29

3.1 Improving flowability and reducing storage agglomeration of metformin hydrochloride through QESD crystallization	29
3.2 Enabling the direct compression of metformin hydrochloride through QESD crystallization	31
3.3 Towards a better understanding of the role of stabilizers in QESD crystallizations	33
3.4 Increasing the batch size of a QESD crystallization by using a MSMPR crystallizer	35
4. Conclusion.....	37
5. Summary and Outlook	41
6. Danksagung.....	42
7. Eidesstattliche Erklärung.....	45

List of publications and contributions

Published manuscripts

J. Hansen, P. Kleinebudde, *Improving flowability and reducing storage agglomeration of metformin hydrochloride through QESD crystallization*, European Journal of Pharmaceutics and Biopharmaceutics, 159 (2021) 170-176.

- Own contribution: 65 %
- JH provided contribution to the conception of the work, especially the development of the crystallizer and crystallization formulation. Furthermore, JH acquired and analyzed the data while its interpretation was done together with PK. JH drafted the manuscript and changed the sections corrected by PK.

J. Hansen, P. Kleinebudde, *Enabling the direct compression of metformin hydrochloride through QESD crystallization*, International Journal of Pharmaceutics, 605 (2021) 120796.

- Own contribution: 75 %
- JH provided contribution to the conception of the work, especially regarding setting requirements for direct compression and simulating industrial manufacturing. Furthermore, JH acquired and analyzed the data while its interpretation was done together with PK. JH drafted the manuscript and changed the sections corrected by PK.

J. Hansen, P. Kleinebudde, *Towards a better understanding of the role of stabilizers in QESD crystallizations*, Pharmaceutical Research, accepted, *published online* (2022).

- Own contribution: 80 %
- JH provided contribution to the conception of the work, especially regarding the development of the novel screening method for QESD crystallization which was first tested during a "Wahlpflichtfachpraktikum". Furthermore, JH acquired and analyzed the data while its interpretation was done together with PK. JH drafted the manuscript and changed the sections corrected by PK.

J. Hansen, P. Kleinebudde, *Increasing the batch size of a QESD crystallization by using a MSMPR crystallizer*, *Pharmaceutics*, 14 (2022) 1227.

- Own contribution: 75 %
- JH provided contribution to the conception of the work, especially regarding the development of the MSMPR crystallizer and the tracer measurements. Furthermore, JH acquired and analyzed the data while its interpretation was done together with PK. JH drafted the manuscript and changed the sections corrected by PK.

Congress presentations

J. Hansen, P. Kleinebudde, 2021. *Minimierung der Brückenflüssigkeit bei sphärischer Agglomeration (Reducing the amount of bridging liquid during spherical agglomeration)*. Poster presentation, Jahrestreffen ProcessNet-Fachgruppe: Agglomerations- und Schüttguttechnik, online

J. Hansen, P. Kleinebudde, 2021. *Improving flowability and reducing storage agglomeration of metformin hydrochloride through QESD crystallization*. Oral presentation, 12th World Meeting on Pharmaceutics, Biopharmaceutics and Pharmaceutical Technology, online

J. Hansen, P. Kleinebudde, 2021. *Enabling the direct compression of metformin hydrochloride through QESD crystallization*. Poster presentation, 12th World Meeting on Pharmaceutics, Biopharmaceutics and Pharmaceutical Technology, online

J. Hansen, P. Kleinebudde, 2022. *Einfluss der Emulgatoren einer QESD-Kristallisation auf die Tablettenfestigkeit (Influence of emulsifiers used during a QESD crystallization on tablet strength)*. Poster presentation, Jahrestreffen ProcessNet-Fachgruppe: CFD, Mischvorgänge, Agglomerations- und Schüttguttechnik, Leipzig, Germany

J. Hansen, P. Kleinebudde, 2022. *Clarifying the role of hypromellose as a stabilizer for QESD crystallizations*. Poster presentation, 13th World Meeting on Pharmaceutics, Biopharmaceutics and Pharmaceutical Technology, Rotterdam, Netherlands

J. Hansen, P. Kleinebudde, 2022. *Increasing the lab-scale production size of a QESD crystallization using a MSMPR setup*. Poster presentation, 13th World Meeting on Pharmaceutics, Biopharmaceutics and Pharmaceutical Technology, Rotterdam, Netherlands

List of Abbreviations

Active pharmaceutical ingredient (API)

Biopharmaceutics classification system (BCS)

Bridging liquid (BL)

Celecoxib (CEL)

Continuous manufacturing (CM)

Cyclooxygenase (COX)

European Pharmacopoeia (Ph. Eur.)

Focused beam reflectance measurement (FBRM)

Metformin hydrochloride (MF)

Mixed-suspension mixed-product removal (MSMPR)

Non-insulin-dependent diabetes mellitus (NIDDM)

Particle size distribution (PSD)

Process analytical tools (PAT)

Quasi-emulsion solvent-diffusion (QESD)

Scanning electron microscope (SEM)

Spherical agglomerate (SA)

Volumetric flow (\dot{V})

World Health Organization (WHO)

1. Introduction

1.1 General

Particle engineering in the pharmaceutical context is the process of modifying the morphology, i.e. the shape, surface structures, size etc. and thereby the micromeritic properties of an active pharmaceutical ingredient (API) or excipient without changing its chemical, pharmacological or crystalline properties. Advantages of such techniques are that the flowability [1-3], tableability [4-6] and dissolution profile [7] of a substance can be improved while maintaining its pharmaceutical activity. Hollow, spherical particles offer several advantages, as they often have good flowability, tableability and a large specific surface area. These free-flowing powders can then be directly compressed into tablets without the need for intermediary production steps, such as granulation or spray drying.

Reducing the amount of intermediary production steps is of great economic advantage as fewer production machines are required and therefore a smaller manufacturing footprint can be realized. Furthermore, the overall energy consumption of the process can be reduced as, e.g. the drying of granules or pellets is energy intensive. A reduction in the production time is feasible so that changes in market demand can be responded to more quickly.

Producing spherical particles of a material is often achieved by confining the space in which it can solidify/crystallize, such as in droplets during spray drying [8] or emulsion evaporation [9, 10]. Another possibility is the use of spherical crystallization techniques where material is crystallized and/or agglomerated within transient emulsions. An advantage of using spherical crystallization techniques as a platform for particle engineering is that a crystallization is already often part of the final purification step during an API or excipient synthesis, so that no additional equipment or production steps are required to produce a product with improved micromeritic properties.

1.2 Crystallization

1.2.1 General

A crystallization is often part of the final production step of an API or excipient. It can be used as a purification step as solutes are selectively crystallized from a mother liquor. The solids are removed from the slurry and washed using a variety of solid-liquid separation systems, such as filtration or centrifugation. Every substance has a defined solubility in a specific solvent at a specific temperature and pressure, at which point no further material can dissolve under equilibrium conditions. The driving force behind nucleation and subsequent crystal growth is the achievement of supersaturation within the crystallization system. When crystallizing from a solution, supersaturation can be achieved by, e.g. reducing the temperature of a solution, removing solvent through evaporation or the addition of antisolvent. Choosing a suitable crystallization technique depends, e.g. on the slope of the solubility curve (Fig. 1, curve B) and the tendency of the material to form different polymorphs/solvates. If the solubility curve of an API is shallow for example, an antisolvent crystallization may be preferential compared to a cooling one as higher yields may be achieved [11].

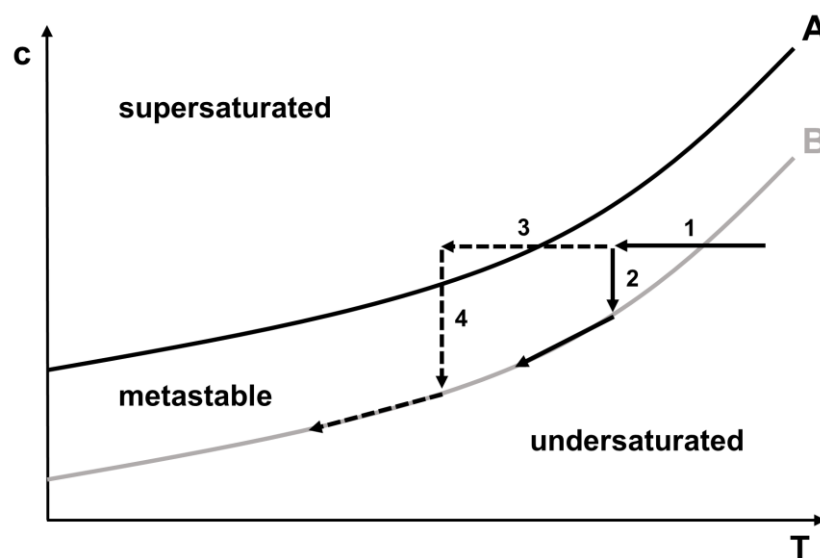

Figure 1. Ostwald-Miers diagram showing the metastable zone which is defined as the area between the curve of supersaturation (A) and the solubility curve (B).

The Ostwald-Miers diagram (Fig. 1) can be used to explain the phenomena which occur during crystallization. The solubility curve (Fig. 1, curve B) divides the area into the stable, undersaturated solution and the unstable, metastable and supersaturated areas. While the solute remains in solutions as long as the metastable region is not yet reached, crossing the solubility curve (1) can lead to crystal growth if seed particles are present in the slurry. Further increasing the degree of supersaturation of a solution into the supersaturated zone will lead to spontaneous nucleation (3) and subsequent crystal growth. The supersaturation will be reduced in both cases (2 and 4) and subsequent crystal growth under equilibrium conditions will occur along the solubility curve.

1.2.2 Crystal morphology

The three dimensional shape of a crystal is often referred to as its habit and influences the flowability and further characteristics of a product. The habit depends on the chemical structure of the material and on the relative growth rates of the different crystal faces during crystallization. These may depend on the presence of impurities, the type of solvent used, the mixing conditions and the rate of cooling during the crystallization [12]. Common crystal habits of APIs include needles (e.g. salicylic acid [13]), plates (e.g. etodolac [14]), orthorhombic (e.g. paracetamol [15]) and cuboid (e.g. L-alanine [16]). While needles and plates often exhibit poor flowability and poor performance during filtration and washing, cuboid crystals show an improved performance [17].

1.2.3 Polymorphs and solvates

Polymorphism describes the fact that a single chemical compound can form different crystal structures which can differ in their physical and crystalline properties. As different polymorphs of a chemical compound may differ in their thermodynamic stability, the transition from one polymorph to a more stable one is possible under storage conditions through, e.g. changes in temperature, humidity and the presence of impurities [18]. Therefore, the stability of the desired polymorph of an API has to be guaranteed over the shelf-life of the drug. Knowing which polymorphs of an API exist and their stability is of great importance, especially as their solubilities can differ and therefore affect the dissolution rate and finally the bioavailability of an API. Polymorphs may also show differences in their mechanical properties which can, e.g. affect the strength of tablets [19]. Differentiation of different polymorphs can be determined using powder X-ray diffraction and differential scanning calorimetry. Selective crystallization of the desired polymorph can be achieved by seeding the supersaturated solution with finely ground particles of the desired polymorph [20].

1.2.4 Crystallizers

1.2.4.1 General

Different crystallizers are commercially available depending on the type of crystallization process required for a certain material and desired throughput. Their dimensions and geometries depend on the desired batch size as well as, e.g. the required mixing conditions and rate of heat transfer. Lab-scale crystallizers for batch and continuous production are readily available and can be modified to meet the specific requirements of the process. The advantages of batch crystallizers are that the processes are well known and described in literature and that the experimental setups are often quite simple and cheap. Disadvantages include the limitation in batch size due to the limited dimensions of the crystallizers themselves. Furthermore, the process conditions can change within a single run as, e.g. the solvent fraction of the mother liquor can increase during an antisolvent crystallization. Therefore, transferring a conventional batch crystallization into a continuously operated one can yield several benefits as batch size is often only limited by run time and constant operating conditions at steady-state can be achieved. This transfer process can however be challenging as the mixing quality and operating conditions during slurry transfer have to be maintained [21]. Furthermore, continuous crystallizers such as oscillatory flow baffled crystallizers are more expensive than conventional round-bottom crystallizers.

1.2.4.2 Lab-scale batch crystallizers

Typical lab-scale batch crystallizers (Fig. 2) are made of a jacketed crystallizer used to control the temperature of the mother liquor. The addition of API solution or antisolvent can be done either onto the surface or directly into the slurry. Probes, such as Pt-100 for temperature monitoring or other process analytical tools (PAT) such as focused beam reflectance measurements (FBRM) for the in-line measurement of particle size distribution (PSD) can be implemented. The crystallizers are typically equipped with an overhead stirrer to ensure homogeneous mixing of the suspension.

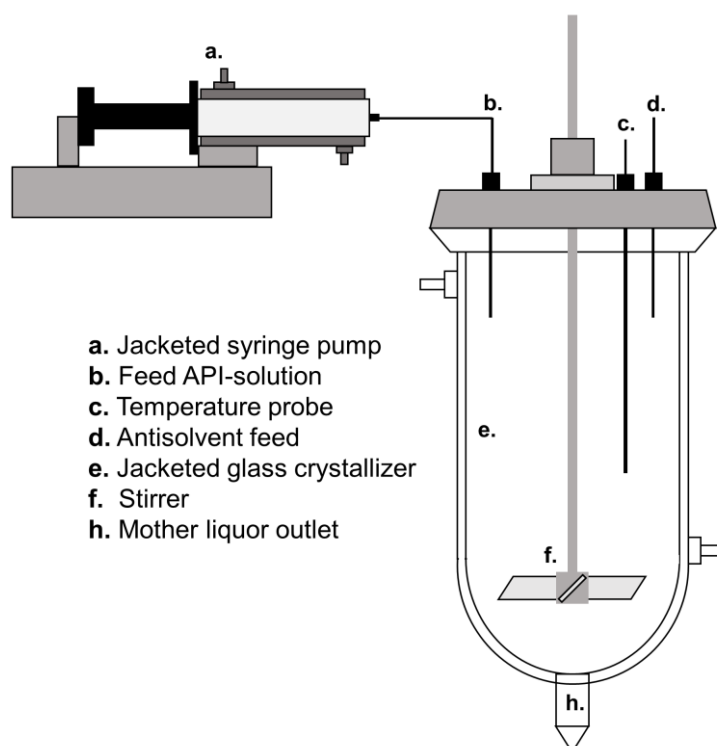

Figure 2. Setup of a lab-scale batch crystallizer equipped with a syringe pump for the transfer of a solution or solvent.

The type of stirrer used (pitch-blade impeller, anchor stirrer, Rushton turbine...) and its dimension relative to the crystallizer depends on the desired primary flow pattern (axial and/or radial stirring) and required dispersion forces in the system [22, 23]. The axial flow produced by propeller mixers (Fig. 3B) is suited for dissolution processes and liquid-liquid blending. Pitched-blade stirrers (Fig. 3A) provide both axial and radial flow which results in higher shear forces and more turbulence within the system. This can be useful for the mixing of emulsions. Paddle stirrers (Fig. 3C) produce tangential flow which is often required for the mixing of highly viscous fluids and suspensions with a high solid fraction.

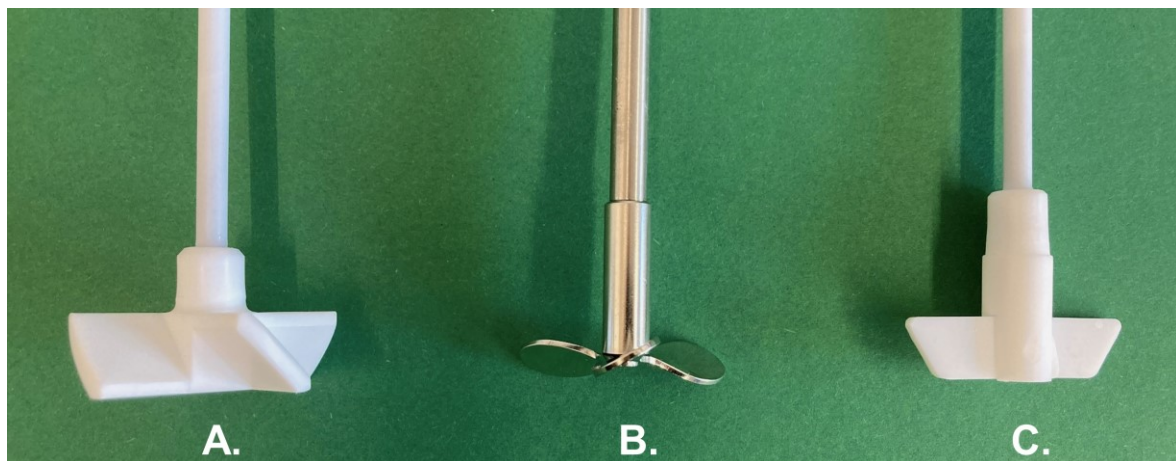

Figure 3A. 45° pitch-blade stirrer, **B.** propeller stirrer and **C.** paddle stirrer

Depending on the type of crystallization (antisolvent, cooling, evaporation...) different auxiliary components can be connected to the crystallizer such as pumps for antisolvent, vacuum pumps or distillation bridges. At the end of a crystallization run, the suspension is removed from the crystallizer and a solid-liquid separation is performed using, e.g. filtration, followed by a washing step and subsequent drying of the material. Insufficient washing can lead to the presence of impurities or agglomeration, as material dissolved in the mother liquor can crystallize during drying which leads to the formation of solid bridges between single crystals.

1.2.3.3 Mixed-suspension mixed-product removal (MSMPR) crystallizers

Continuous manufacturing (CM) offers several advantages compared to the traditional batch production of pharmaceuticals. For one, CM allows for a reduction in production time as intermediates no longer need to be stored and the batch can be released in real time. Validated in-line or on-line measurements, such as Raman spectroscopy [24] or dynamic image analysis [25], can be used to monitor and control the system to ensure uniformity of the material and increased yield [26]. Furthermore, batch size is no longer limited by the equipment dimensions, as the production capacity is only limited by the run time of the machine. This also allows for a reduction in the footprint of the manufacturing line. Transferring a batch process into a continuous one can however be difficult as new equipment types, PATs and qualification/validation processes have to be designed and understood.

MSMPR crystallizers are simple continuous crystallizers which can be built using existing batch crystallizers. Steady-state operation is achieved by continuously adding antisolvent and product solution to the crystallizer while simultaneously removing product at the outlet (Fig. 4). Just as in batch mode, process conditions can be adjusted by, e.g. the stirring speed or jacket temperature. However, additional parameters such as the mean residence time or solvent fraction of the mother liquor can be adjusted by changing the initial fill-level or pump rates of the respective liquids [27]. Several MSMPR crystallizers can also be linked together in series, so that certain operations, such as the initial crystallization and subsequent agglomeration, can be decoupled and occur in separate crystallizers. Thereby a higher degree of control can be achieved at each stage which allows for, e.g. a narrower PSD of the crystals and subsequent better processing in further downstream operations [28]. Recycling the mother liquor can reduce the amount of solvents required and increase production yield [29]. The batch size is no longer limited by the volume of the crystallizer and the solid fraction of the slurry but only by its runtime. Issues with long run times however include the encrustation of the walls and stirrer of the crystallizer, blockage of transfer pumps/lines and fouling of PAT

probes. Furthermore, the implementation of an impinging jet might be required to ensure ideal mixing conditions during anti-solvent or reaction crystallizations [30].

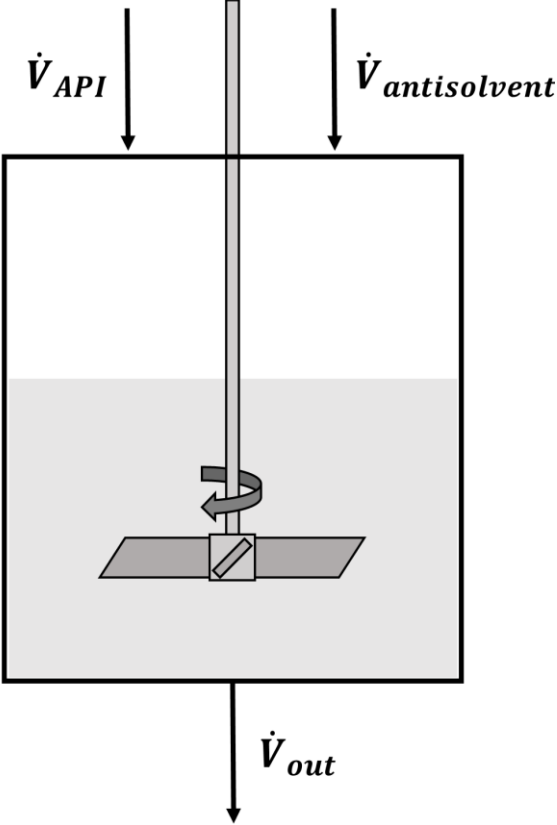

Figure 4. Schematic representation of a MSMPR crystallizer used for an antisolvent crystallization.

1.3 Spherical crystallization

1.3.1 General

Spherical crystallizations can be divided into quasi-emulsion solvent-diffusion (QESD) crystallizations, spherical agglomerate (SA) and the ammonia-diffusion method [31]. All of the methods have in common that they are based on antisolvent crystallizations, where crystallization and agglomeration occur in a single production step with the help of transient emulsions. Both QESD [32] and SA [33] were first described by Kawashima et al. in the 80's. The type of crystallization method used depends on properties of the API or excipient, such as solubility in water and on the desired morphology / attributes of the obtained particles.

1.3.2 Quasi-emulsion solvent-diffusion method

QESD crystallizations can be used to generate spherical, hollow particles of an API or excipient which can have improved flowability and tabletability compared to the unprocessed raw material [6, 32, 34]. Crystallization and agglomeration occurs within transient emulsion droplets which limit the space in which the agglomerates can be formed and grow (Fig. 5). A solution of an API or excipient is dispersed in a suitable, miscible antisolvent. Choosing the correct solvent and antisolvent can be difficult, as the choice of the solvents is often very limited due to the required solubilities of the API in the solvent and antisolvent and their miscibility [35]. Furthermore, the batch size can be limited if the solvents are only partially miscible as free solvent leads to the formation of a paste-like consistency of the agglomerates. A typical example for this is the use of water/ethyl acetate [35-38] as solvent and antisolvent.

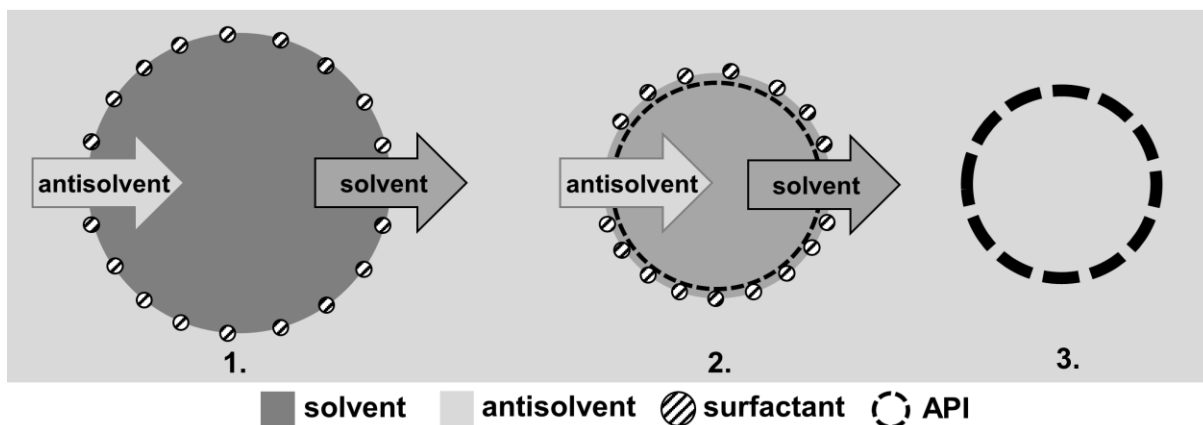

Figure 5. Schematic representation of agglomerate formation during QESD crystallization.

The counter diffusion of solvent and antisolvent from the emulsion droplets will lead to the formation of a supersaturated API solution within the emulsion droplets (Fig. 5, 1.). Hereby, the local supersaturation will be highest at the interface due to the proximity to the outer antisolvent phase [39]. Furthermore, heat transfer from the emulsion droplet, if a heated API solution is used, can further increase the supersaturated state within the droplets. The supersaturation of the droplet solution will lead to nucleation and crystal growth of the API once the curve of supersaturation (Fig. 1, B) is crossed. In a well stabilized QESD system, nucleation and crystal growth will begin initially at the interface of the droplets, as the local concentration of solute will be highest here as the diffusion of solvent from the center of the droplet cannot fully compensate for the intrusion of antisolvent [39]. Therefore, a crust at the interface is formed to which further dissolved API from the droplet can crystallize (Fig. 5, 2.). This leads to the formation of spherical, hollow agglomerates (Fig. 6).

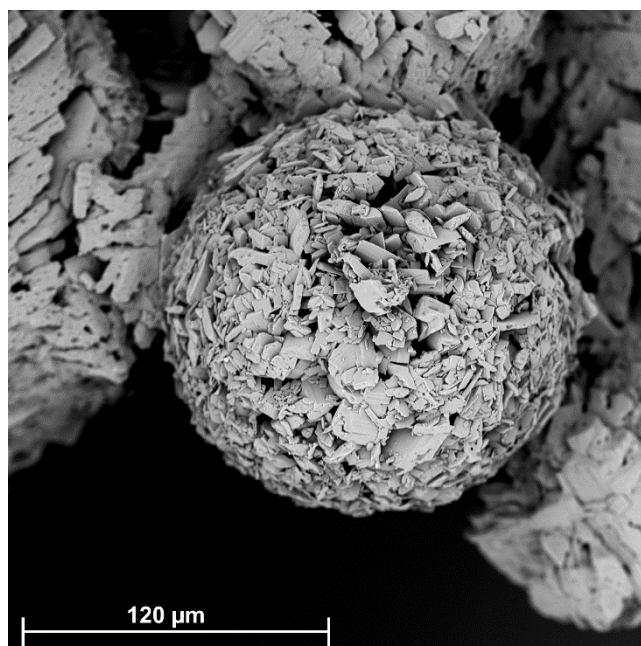

Figure 6. SEM image of an API particle produced via QESD crystallization.

Antisolvent crystallizations usually do not yield spherical particles as the counter diffusion of the solvents is too fast for the formation of emulsion droplets. The addition of stabilizers may be required to increase the stability of the transient emulsion and reduce the rate of solvent diffusion [40-42]. The use of both non-ionic surfactants [35, 37, 38, 43] and polymeric stabilizers [1, 34, 42, 44] have been described for QESD crystallizations. The stabilizer is most commonly added to the aqueous phase as it is often not soluble in the organic one. This is one of the reasons why many QESD crystallization formulations can be found for poorly water soluble APIs [1, 37, 42, 44] while only a few exist for APIs with a high solubility in water [5, 35, 43]. The addition of the stabilizer to the aqueous API solution can be problematic as its cloud point may be exceeded when heating the solution to ensure complete drug dissolution.

It is important to note that typical polymeric stabilizers for QESD crystallizations, such as hypromellose and polyvinylpyrrolidone, not only increase the viscosity of an aqueous solution but also lower its surface tension. Choosing a suitable stabilizer for the transient emulsion can be challenging as both the strength of specific interactions between the API and polymeric stabilizer [34], the viscosity of the solutions [42] and the solubility in the respective solvents

can influence the agglomerate properties. Residual amounts of the stabilizer adsorbed to the QESD particles can influence the agglomerate properties, as reduced punch sticking during tableting [34] and improved dissolution rates [45] have been reported.

The agglomeration of crystals from a suspension can however also pose certain issues. For one, mother liquor can be trapped within voids between the primary particles which can increase the residual solvent level and lead to the presence of impurities in the final product [46]. Furthermore, hollow, spherical agglomerates can have an increased porosity and therefore reduced bulk density compared to the raw material which can lead to issues during direct compression. These include tablet capping due to insufficient deaeration [47] and reduced flow rate and subsequent slow die filling during tableting [48].

The PSD of QESD agglomerates can be modified by changing system parameters of the crystallizer. For one, the particle size of QESD agglomerates depends on the droplet size of the transient emulsion [39]. It can be reduced by increasing the rotational speed of the stirrer and therefore increasing the input of mechanical energy into the system. If the rotational speed of the stirrer is set too low, a sedimentation of the particles occurs while an increased amount of fines can be produced if the speed is set too high [39]. The optimal stirrer speed has to be evaluated separately for each system as it depends on the stirrer type and size, dimensions of the crystallizers and the viscosity of the suspension. The fill volume of the crystallizer can also have an influence on the droplet size at a constant stirrer speed, as the mechanical energy input into the system per unit volume of antisolvent increases with decreasing fill level [38].

A reduction in the temperature of the antisolvent leads to the formation of smaller agglomerates as the rate of counter diffusion decreases at lower temperatures. This reduces the gradient of supersaturation within the transient emulsion droplets so that the crust formation is delayed to a smaller droplet size [37, 39]. Increasing the solvent fraction of the mother liquor has a similar effect on the particle size, as diffusion rates decrease with an increased solvent fraction of the outer phase of the emulsion [39]. Therefore, during batch operation, the agglomerate size will decrease with increasing amount of API solution fed to the crystallizer.

1.3.3 Spherical agglomeration

During SA an API or excipient is first crystallized, often using an antisolvent crystallization [4, 14, 33], and the obtained particles are agglomerated in suspension using a so called “bridging liquid” (BL). The BL has to be poorly miscible in the mother liquor so that emulsion droplets are formed. The primary particles of the suspension are wetted by the BL and consequently agglomerated through the negative capillary pressure and interfacial tension present in the system [31]. Collisions of the particles with the wall, stirrer and other particles cause a densification of the particles and therefore liberation of the bridging liquid to the surface of the particles. There it can bind further particles from the suspension [49]. A certain solubility of the material in the bridging liquid is required so that material bridges between single particles can be formed during crystallization and drying. Using too little bridging liquid leads to insufficient agglomeration whereas an excess results in soft and pasty agglomerates [49, 50]. Typical bridging liquids used for poorly water soluble drugs include toluene [51, 52], dichloromethane [4] and chloroform [53]. An issue when working with these BLs is that low residuals solvent levels have to be guaranteed due to their toxicity. In contrast to the particles obtained via QESD crystallizations, those produced through the SA method are most commonly solid [37] but show similar advantages regarding their flowability, dissolution and tableting performance.

1.3.4 Ammonia-diffusion method

The ammonia-diffusion method can be used to spherically crystallize substances which show a pH-dependent solubility [31]. The API is dissolved in an aqueous ammonia solution where ammonia also acts as the BL. The solution is dispersed in a mixture of an antisolvent, which has to be miscible with water and ammonia, and a water-immiscible solvent, such as a hydrocarbon [31]. Crystallization occurs as the water-miscible antisolvent diffuses into the solution droplets and causes precipitation of the drug. The water immiscible solvent is responsible for the liberation of ammonia from the solvent droplets, thereby limiting its function as a BL. Agglomerate size can be controlled by the amount of ammonia available as a BL [54].

1.4 Tableting and direct compression

Even though tablets are one of the oldest manufactured pharmaceutical dosage forms, they are still of great relevance due to their low production cost and high throughput capacity compared to other dosage forms. Currently, oral drug formulations have a market share of about 90 % [55]. Tableting is the act of compressing powder or granule blends in a die using punches of various size and shape. Different tablet presses are available on the market, ranging from simple, small hydraulic presses used for academic studies or the production of small batches for clinical studies to large rotary presses which can produce > 1,000,000 tablets per hour.

The strength of a tablet results from the sum of the cohesive and adhesive forces present within the tablet. During compression bonds between single particles can be formed through their plastic deformation and breakage which can lead to inter-locking of the particles and an increase in the intermolecular forces, e.g., Van der Waals forces, between them. Furthermore, sintered and solid-state bridges can be formed which can further increase tablet strength [56]. Hollow agglomerates, like those produced through spray agglomeration or QESD crystallization, offer the advantage that they consist of small primary particles with a high specific surface area. The agglomerates break during compression which leads to the formation of new bonding surfaces to increase tablet strength [6]. Regulatory agencies do not explicitly specify a threshold for the required strength of tablets, however a tensile strength of > 2 MPa is seen as adequate in literature [57]. If tablets are too weak, they may disintegrate during down-stream processes such as coating, packaging and transport.

Typical powder blends for tableting contain the API along with solid binders (e.g., hypolose and microcrystalline cellulose), fillers (e.g., lactose and mannitol), disintegrants (e.g., crospovidone), lubricants (e.g., magnesium stearate and sodium stearyl fumarate) and glidants (e.g., fumed silica). To ensure a good uniformity of the powder blend, different mixers can be used to incorporate the various ingredients. Choosing a suitable mixer type depends on the

flow characteristics of the powder, the batch size, operational mode (batch or continuous) and drug load.

The simplest form of tableting is the direct compression of a powder blend into tablets. This however cannot always be realized if the blend shows poor flowability which leads to an inhomogeneous filling of the die during tableting. The addition of further excipients [56] or an intermediary wet or dry granulation step may be required [58]. Direct compression can reduce the production time and energy consumption of the manufacturing process. It can also be favorable for small batch sizes, as product is lost during the startup and shutdown of an intermediary production step such as twin-screw granulation. Furthermore, direct compression can also be of advantage when handling highly potent APIs, as a reduction in the number of processing steps can reduce the risk of contamination.

After compression, tablets can be further processed using a coater to modify the dissolution behavior, protect the API from humidity, change the tablets cosmetically or protect from a bitter taste [59]. Finally, tablets are filled into suitable primary packages to protect them from environmental influences, mechanical stress and to avoid unwanted contact with the API.

1.5 Prerequisites for direct compression

1.5.1 General

Several quality attributes of a powder blend have to be met to ensure that tablets produced via direct compression fulfill the specifications set by the pharmacopoeia. For one, good flowability is essential, as without it, inhomogeneous filling of the die and precompaction in the hopper can occur. Furthermore, the powder blend has to show adequate tableability without the need for a wet granulation step to improve the deformation behavior of the material [60]. Directly compressing low-dose tablets can also be challenging as blend uniformity cannot always be guaranteed. An intermediary granulation step can be used to improve the distribution of an API in a powder blend and reduce the segregation tendency [61].

1.5.2 Flowability

Good flowability of a powder is a requirement for many process steps during pharmaceutical manufacturing such as blending, powder feeding, capsule filling and tableting. Poor flowability can result in inhomogeneous powder blends after mixing, blockage of transfer lines and mass and content variations of the final dosage forms. High forces of adhesion to the walls of a container and cohesive forces through high moisture levels can lead to poor flowability as gliding planes cannot be established easily [62]. Particle morphology can also have a strong impact on the flowability of substances. While needle-shaped particles, e.g. salicylic acid [13], often show very poor flowability due to the interlocking of particles, spherical particles with a smooth surface, like those produced through, e.g. spray drying or fluid-bed granulation, show an improved flowability [63]. Furthermore, increased residual moisture content which can result from incomplete drying or through the hygroscopic character of a product can lead to higher adhesive and cohesive forces which reduce flowability [64]. On the other hand, very low moisture levels can lead to increased electrostatic charges which can cause adhesion to manufacturing equipment and storage containers [65].

The flow characteristics of a powder can be differentiated into free-flowing and cohesive. There are different standardized methods available to classify the flowability of powders and granules, however they can differ in their suitability to discriminate between different mixtures [66]. The European Pharmacopoeia (Ph. Eur.) describes the use of the Hausner ratio (2.9.34. [67]), angle of repose, flow through an orifice and shear cell methods (2.9.36. [68]) to characterize powder flowability. These methods can differ in their suitability for certain powder types, as shear cell measurements can be unsuitable for free-flowing materials [69]. The test methods also simulate different operations. The measurement of the angle of repose and flow through an orifice can simulate the powder flow from a container into a hopper while the Hausner ratio can be used to estimate the compaction of powder in a hopper caused by gravity. If a powder has poor flowability, direct compression into tablets might not be possible, as a homogeneous blend and even filling of the die during tableting cannot be ensured. Glidants, such as fumed silica [62], can be added to reduce the cohesive forces of the particles. Alternatively, an intermediary processing step, such as granulation, can be performed to increase the particle size, reduce the number of interparticular contact points and thereby increase flowability.

1.5.3 Storage agglomeration

The agglomeration of bulk powders during storage can be a major issue during the production lifecycle of a pharmaceutical dosage form. Bulk powders have to be stored between single production steps and if the powder tends to agglomerate, poor flowability, inhomogeneous content uniformity and an inability to perform subsequent manufacturing steps may be the consequence. Tendencies towards storage agglomeration can depend on the solid-state of a product, its hygroscopicity [70], particle size and morphology [71], electrostatic attraction [72] and plastic deformation at low pressures [73]. Some APIs, such as metformin hydrochloride, have such a high tendency towards storage agglomeration that the bulk API has to be freshly milled and processed further within 24 h [74].

1.6 Problematic APIs for direct compression

1.6.1 General

Certain physical properties of an API can make it unsuitable to perform direct compression. For one, poor flowability and low bulk density can lead to inhomogeneous die filling and segregation during tableting. Furthermore, when APIs with poor tabletability are incorporated into highly drug loaded powder blends, poor tablet strength can result after compression. Therefore, changing the morphology and micromeritic properties of an API through particle engineering can allow for an improved performance during tableting.

1.6.2 Metformin hydrochloride

Metformin hydrochloride (1,1-dimethylbiguanidine hydrochloride, Fig. 7) is a drug used in the treatment of non-insulin-dependent diabetes mellitus (NIDDM, type 2 diabetes). According to the World Health Organization (WHO), approximately 400 million people suffered from this disease in 2014 [75]. MF was first synthesized by Werner and Bell [76] in 1922 and its ability to lower blood sugar was first reported by Hesse et al. in 1929 [77]. Nowadays, it is a first-line pharmacological choice in the treatment of type 2 diabetes and was added to the WHO's list of essential medicines in 2011 [78]. The global market value of MF was estimated to be \$248 million in 2019 [79].

MF increases the bodies insulin sensitivity by decreasing the hepatic glucose output and enhancing the peripheral glucose uptake. Furthermore, an increased intestinal usage of glucose and a decreased fatty-acid oxidation have been reported [80]. A further advantage of MF is that it does not promote weight gain unlike sulfonylureas, as it reduces hyperglycemia without insulin stimulation [81]. The recommended daily maximum dose is 2550 mg [80].

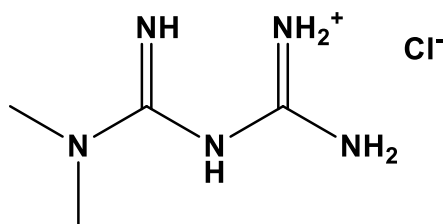

Figure 7. Chemical structure of metformin hydrochloride.

MF is administered orally in the form of highly drug loaded tablets with doses of 500, 850 and 1000 mg available on the German market [82]. It belongs to the group of biopharmaceutical classification system (BCS) class 3 drugs, as it has a high solubility and low permeability [83]. The bulk powder has very poor flowability as it crystallizes in the shape of needles [84]. Furthermore, it tends to agglomerate under storage as plastic deformation can already be observed at very low compaction pressures which can lead to the interlinking of the powder particles [74]. Therefore, the material always has to be freshly milled and a direct compression of highly drug loaded tablets could not yet be realized. Intermediary production steps, such as dry granulation [74], are required to improve the flowability of the material and therefore enable its tableting.

1.6.3 Celecoxib

Celecoxib (CEL, 4-[5-(4-methylphenyl)-3-(trifluoromethyl)-1H-pyrazol-1-yl]benzene-sulfonamide, Fig. 8) is a poorly water soluble API which acts as a cyclooxygenase (COX) inhibitor. It shows a selectivity towards COX-2 compared to COX-1 which reduces the risk of peptic ulceration. It is used as a nonsteroidal anti-inflammatory drug in the treatment of pain and inflammatory diseases such as osteoarthritis, menstrual pain and rheumatoid arthritis [85].

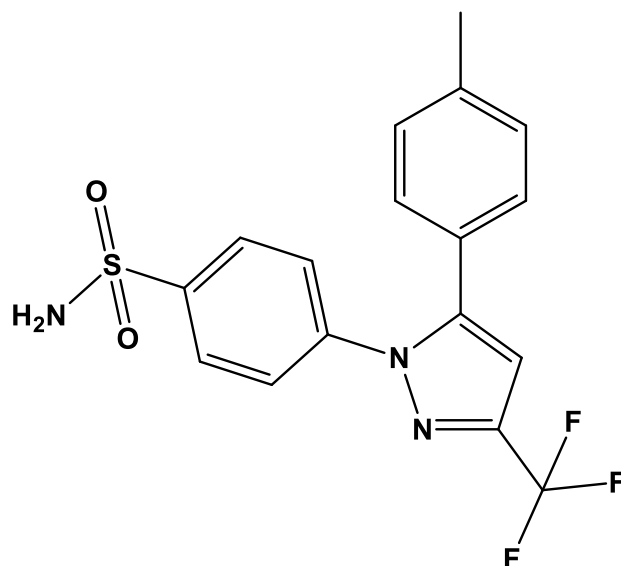

Figure 8. Chemical structure of celecoxib.

Celecoxib has a poor solubility in water and belongs to the BCS class II drugs [86]. Due to the poor tableting behavior of celecoxib (Form III), i.e. poor flowability, low bulk density and tendency for tablet lamination, only capsules are available on the market [87]. Capsule filling is however more expensive and slower compared to tableting [88]. Another key issue of the API is the tendency for punch-sticking during tableting which can lead to encrusted punches [89]. Chen et al. [34] demonstrated that a QESD crystallization can be used to create spherical, free flowing CEL powder with reduced punch-sticking properties due to the presence of a protective hypromellose film on the API crystals. The crystallization formulation consists of a solution of CEL in ethyl acetate which was crystallized in an aqueous hypromellose solution.

References

- [1] H. Chen, C. Wang, H. Kang, B. Zhi, C.L. Haynes, A. Aburub, C.C. Sun, Microstructures and pharmaceutical properties of ferulic acid agglomerates prepared by different spherical crystallization methods, *International Journal of Pharmaceutics*, 574 (2020) 118914.
- [2] W. Li, J. Yang, S. Du, E. Macaringue, Y. Wang, S. Wu, J. Gong, Preparation and formation mechanism of l-valine spherulites via evaporation crystallization, *Industrial & Engineering Chemistry Research*, 60 (2021) 6048-6058.
- [3] H. Chen, H. Xu, C. Wang, H. Kang, C.L. Haynes, M.K. Mahanthappa, C.C. Sun, Novel quasi-emulsion solvent diffusion-based spherical cocrystallization strategy for simultaneously improving the manufacturability and dissolution of indomethacin, *Crystal Growth & Design*, 20 (2020) 6752-6762.
- [4] H. Chen, C. Wang, C.C. Sun, Profoundly improved plasticity and tableability of griseofulvin by in situ solvation and desolvation during spherical crystallization, *Crystal Growth & Design*, 19 (2019) 2350-2357.
- [5] D. Lamesic, O. Planinsek, Z. Lavric, I. Ilic, Spherical agglomerates of lactose with enhanced mechanical properties, *International Journal of Pharmaceutics*, 516 (2017) 247-257.
- [6] H. Chen, A. Aburub, C.C. Sun, Direct compression tablet containing 99% active ingredient—a tale of spherical crystallization, *Journal of Pharmaceutical Sciences*, 108 (2019) 1396-1400.
- [7] A. Sano, T. Kuriki, Y. Kawashima, H. Takeuchi, T. Hino, T. Niwa, Particle design of tolbutamide by the spherical crystallization technique. V. Improvement of dissolution and bioavailability of direct compressed tablets prepared using tolbutamide agglomerated crystals, *Chemical and Pharmaceutical Bulletin*, 40 (1992) 3030-3035.
- [8] R. Vehring, Pharmaceutical particle engineering via spray drying, *Pharmaceutical Research*, 25 (2008) 999-1022.
- [9] A.I. Toldy, A.Z.M. Badruddoza, L. Zheng, T.A. Hatton, R. Gunawan, R. Rajagopalan, S.A. Khan, Spherical crystallization of glycine from monodisperse microfluidic emulsions, *Crystal Growth & Design*, 12 (2012) 3977-3982.
- [10] J.L. Quon, K. Chadwick, G.P. Wood, I. Sheu, B.K. Brettmann, A.S. Myerson, B.L. Trout, Templated nucleation of acetaminophen on spherical excipient agglomerates, *Langmuir*, 29 (2013) 3292-3300.
- [11] R. Davey, J. Garside, 2 Phase equilibria and crystallization techniques, in: *From molecules to crystallizers: An Introduction to Crystallization*, Oxford University Press, Oxford, UK, 2006, pp. 6-14.
- [12] J. Ulrich, T. Stelzer, Crystallization, in: *Kirk-Othmer Encyclopedia of Chemical Technology*, 2011, pp. 1-63.
- [13] Y. Kawashima, M. Okumura, H. Takenaka, Spherical crystallization: direct spherical agglomeration of salicylic acid crystals during crystallization, *Science*, 216 (1982) 1127-1128.
- [14] S. Jitkar, R. Thipparaboina, R.B. Chavan, N.R. Shastri, Spherical agglomeration of platy crystals: curious case of etodolac, *Crystal Growth & Design*, 16 (2016) 4034-4042.

- [15] P. Di Martino, A. Guyot-Hermann, P. Conflant, M. Drache, J. Guyot, A new pure paracetamol for direct compression: the orthorhombic form, *International Journal of Pharmaceutics*, 128 (1996) 1-8.
- [16] C. Steenweg, J. Habicht, K. Wohlgemuth, Continuous isolation of particles with varying aspect ratios up to thin needles achieving free-flowing products, *Crystals*, 12 (2022) 137.
- [17] R. Davey, J. Garside, 5 Crystal Morphology, in: *From molecules to crystallizers: An Introduction to Crystallization*, Oxford University Press, Oxford, UK, 2006, pp. 36-52.
- [18] A.N. Martin, H. Leuenberger, *Physikalische Pharmazie: Pharmazeutisch angewandte physikalisch-chemische Grundlagen; mit 163 Tabellen*, Wissenschaftliche Verlagsgesellschaft, Stuttgart, Germany, 2002.
- [19] T. Beyer, G.M. Day, S.L. Price, The prediction, morphology, and mechanical properties of the polymorphs of paracetamol, *Journal of the American Chemical Society*, 123 (2001) 5086-5094.
- [20] S.R. Chemburkar, J. Bauer, K. Deming, H. Spiwek, K. Patel, J. Morris, R. Henry, S. Spanton, W. Dziki, W. Porter, Dealing with the impact of ritonavir polymorphs on the late stages of bulk drug process development, *Organic Process Research & Development*, 4 (2000) 413-417.
- [21] R. Peña, J.A. Oliva, C.L. Burcham, D.J. Jarmer, Z.K. Nagy, Process intensification through continuous spherical crystallization using an oscillatory flow baffled crystallizer, *Crystal Growth & Design*, 17 (2017) 4776-4784.
- [22] I. Houcine, E. Plasari, R. David, Effects of the stirred tank's design on power consumption and mixing time in liquid phase, *Chemical Engineering & Technology: Industrial Chemistry-Plant Equipment-Process Engineering-Biotechnology*, 23 (2000) 605-613.
- [23] R. Chhabra, V. Shankar, Chapter 7 - Liquid Mixing, in: *Coulson and Richardson's Chemical Engineering: Volume 1A: Fluid Flow, Fundamentals and Applications (Seventh Edition)*, Butterworth-Heinemann, Oxford, UK, 2018, pp. 333-377.
- [24] J. Radtke, P. Kleinebudde, Real-time monitoring of multi-layered film coating processes using Raman spectroscopy, *European Journal of Pharmaceutics and Biopharmaceutics*, 153 (2020) 43-51.
- [25] A. Wilms, K. Knop, P. Kleinebudde, Combination of a rotating tube sample divider and dynamic image analysis for continuous on-line determination of granule size distribution, *International Journal of Pharmaceutics: X*, 1 (2019) 100029.
- [26] F. Streil, Real time release for continuous manufacturing of direct compression tablets [conference presentation], in: *2nd APV Continuous Manufacturing Conference*, Freiburg im Breisgau, Germany, 2020.
- [27] Z.K. Nagy, A.E. Hagrasy, J. Litster, Chapter 5: Continuous Crystallization: Equipment and Operation, in: *Continuous Pharmaceutical Processing*, Springer International Publishing, Hoboken, USA, 2020, pp. 129-192.
- [28] R. Peña, Z.K. Nagy, Process intensification through continuous spherical crystallization using a two-stage mixed suspension mixed product removal (MSMPR) system, *Crystal Growth & Design*, 15 (2015) 4225-4236.

- [29] S.Y. Wong, A.P. Tatusko, B.L. Trout, A.S. Myerson, Development of continuous crystallization processes using a single-stage mixed-suspension, mixed-product removal crystallizer with recycle, *Crystal Growth & Design*, 12 (2012) 5701-5707.
- [30] T. Wang, H. Lu, J. Wang, Y. Xiao, Y. Zhou, Y. Bao, H. Hao, Recent progress of continuous crystallization, *Journal of Industrial and Engineering Chemistry*, 54 (2017) 14-29.
- [31] B. Kovačič, F. Vrečer, O. Planinšek, Spherical crystallization of drugs, *Acta Pharmaceutica*, 62 (2012) 1-14.
- [32] Y. Kawashima, T. Niwa, T. Handa, H. Takeuchi, T. Iwamoto, K. Itoh, Preparation of controlled-release microspheres of ibuprofen with acrylic polymers by a novel quasi-emulsion solvent diffusion method, *Journal of Pharmaceutical Sciences*, 78 (1989) 68-72.
- [33] Y. Kawashima, K. Furukawa, H. Takenaka, The physicochemical parameters determining the size of agglomerate prepared by the wet spherical agglomeration technique, *Powder Technology*, 30 (1981) 211-216.
- [34] H. Chen, S. Paul, H. Xu, K. Wang, M.K. Mahanthappa, C.C. Sun, Reduction of punch-sticking propensity of celecoxib by spherical crystallization via polymer assisted quasi-emulsion solvent diffusion, *Molecular Pharmaceutics*, 17 (2020) 1387-1396.
- [35] M. Nocent, L. Bertocchi, F. Espitalier, M. Baron, G. Couarraze, Definition of a solvent system for spherical crystallization of salbutamol sulfate by quasi-emulsion solvent diffusion (QESD) method, *Journal of Pharmaceutical Sciences*, 90 (2001) 1620-1627.
- [36] Y. Kawashima, M. Imai, H. Takeuchi, H. Yamamoto, K. Kamiya, T. Hino, Improved flowability and compactibility of spherically agglomerated crystals of ascorbic acid for direct tableting designed by spherical crystallization process, *Powder Technology*, 130 (2003) 283-289.
- [37] K. Chen, B. Hou, H. Wu, X. Huang, F. Li, Y. Xiao, J. Li, Y. Bao, H. Hao, Hollow and solid spherical azithromycin particles prepared by different spherical crystallization technologies for direct tableting, *Processes*, 7 (2019) 276.
- [38] K. Tahara, M. O'Mahony, A.S. Myerson, Continuous spherical crystallization of albuterol sulfate with solvent recycle system, *Crystal Growth & Design*, 15 (2015) 5149-5156.
- [39] F. Espitalier, B. Biscans, C. Laguerie, Particle design Part B: batch quasi-emulsion process and mechanism of grain formation of ketoprofen, *Chemical Engineering Journal*, 68 (1997) 103-114.
- [40] M. Maghsoodi, A. Nokhodchi, Agglomeration of celecoxib by quasi emulsion solvent diffusion method: effect of stabilizer, *Advanced Pharmaceutical Bulletin*, 6 (2016) 607.
- [41] M. Maghsoodi, L. Barghi, Design of agglomerated crystals of ibuprofen during crystallization: influence of surfactant, *Iranian Journal of Basic Medical Sciences*, 14 (2011) 57-66.
- [42] M. Maghsoodi, D. Hassan-Zadeh, M. Barzegar-Jalali, A. Nokhodchi, G. Martin, Improved compaction and packing properties of naproxen agglomerated crystals obtained by spherical crystallization technique, *Drug Development and Industrial Pharmacy*, 33 (2007) 1216-1224.

- [43] O. Gyulai, P. Szabó-Révész, Z.n. Aigner, Comparison study of different spherical crystallization methods of ambroxol hydrochloride, *Crystal Growth & Design*, 17 (2017) 5233-5241.
- [44] M. Kenji, K. Yoshiaki, T. Hirofumi, N. Toshiyuki, H. Tomoaki, K. Yoichi, Tableting properties of Bucillamine agglomerates prepared by the spherical crystallization technique, *International Journal of Pharmaceutics*, 105 (1994) 11-18.
- [45] A. Sano, T. Kuriki, Y. Kawashima, H. Takeuchi, T. Hino, T. Niwa, Particle design of tolbutamide by the spherical crystallization technique. III.: micromeritic properties and dissolution rate of tolbutamide spherical agglomerates prepared by the quasi-emulsion solvent diffusion method and the solvent change method, *Chemical and Pharmaceutical Bulletin*, 38 (1990) 733-739.
- [46] M. Birch, I. Marziano, Understanding and avoidance of agglomeration during drying processes: a case study, *Organic Process Research & Development*, 17 (2013) 1359-1366.
- [47] G. Vreeman, C.C. Sun, Air entrapment during tablet compression—diagnosis, impact on tableting performance, and mitigation strategies, *International Journal of Pharmaceutics*, 615 (2022) 121514.
- [48] K. Kachrimanis, M. Petrides, S. Malamataris, Flow rate of some pharmaceutical diluents through die-orifices relevant to mini-tableting, *International Journal of Pharmaceutics*, 303 (2005) 72-80.
- [49] J. Thati, A.C. Rasmuson, On the mechanisms of formation of spherical agglomerates, *European Journal of Pharmaceutical Sciences*, 42 (2011) 365-379.
- [50] A. Blandin, D. Mangin, A. Rivoire, J. Klein, J. Bossoutrot, Agglomeration in suspension of salicylic acid fine particles: influence of some process parameters on kinetics and agglomerate final size, *Powder Technology*, 130 (2003) 316-323.
- [51] P.M. Orlewski, B. Ahn, M. Mazzotti, Tuning the particle sizes in spherical agglomeration, *Crystal Growth & Design*, 18 (2018) 6257-6265.
- [52] C.W. Chen, H.L. Lee, K.L. Yeh, T. Lee, Effects of scale-up and impeller types on spherical agglomeration of dimethyl fumarate, *Industrial & Engineering Chemistry Research*, 60 (2021) 11555-11567.
- [53] H. Chen, C. Wang, S. Liu, C.C. Sun, Development of piroxicam mini-tablets enabled by spherical cocrystallization, *International Journal of Pharmaceutics*, 590 (2020) 119953.
- [54] M. Ueda, Y. Nakamura, H. Makita, Y. Imasato, Y. Kawashima, Particle design of enoxacin by spherical crystallization technique. I.: principle of ammonia diffusion system (ADS), *Chemical and Pharmaceutical Bulletin*, 38 (1990) 2537-2541.
- [55] M.S. Alqahtani, M. Kazi, M.A. Alsenaidy, M.Z. Ahmad, Advances in oral drug delivery, *Frontiers in Pharmacology*, 12 (2021) 618411.
- [56] W.A. Ritschel, A. Bauer-Brandl, *Die Tablette: Handbuch der Entwicklung, Herstellung und Qualitätssicherung*, Editio Cantor Verlag, Aulendorf, 2002.
- [57] B.J. Bowles, K. Dziemidowicz, F.L. Lopez, M. Orlu, C. Tuleu, A.J. Edwards, T.B. Ernest, Co-processed excipients for dispersible tablets—part 1: Manufacturability, *AAPS PharmSciTech*, 19 (2018) 2598-2609.

- [58] A. G Mirani, S. P Patankar, V. S Borole, A. S Pawar, V. J Kadam, Direct compression high functionality excipient using coprocessing technique: A brief review, *Current Drug Delivery*, 8 (2011) 426-435.
- [59] V. Elezaj, A. Lura, L. Canha, J. Breitzkreutz, Pharmaceutical development of film-coated mini-tablets with losartan potassium for epidermolysis bullosa, *Pharmaceutics*, 14 (2022) 570.
- [60] O.-R. Arndt, R. Baggio, A.K. Adam, J. Harting, E. Franceschinis, P. Kleinebudde, Impact of different dry and wet granulation techniques on granule and tablet properties: a comparative study, *Journal of Pharmaceutical Sciences*, 107 (2018) 3143-3152.
- [61] R. Chamberlain, H. Windolf, S. Geissler, J. Quodbach, J. Breitzkreutz, Precise dosing of pramipexole for low-dosed filament production by hot melt extrusion applying various feeding methods, *Pharmaceutics*, 14 (2022) 216.
- [62] J. Tomas, S. Kleinschmidt, Improvement of flowability of fine cohesive powders by flow additives, *Chemical Engineering & Technology: Industrial Chemistry-Plant Equipment-Process Engineering-Biotechnology*, 32 (2009) 1470-1483.
- [63] H.P. Goh, P.W.S. Heng, C.V. Liew, Comparative evaluation of powder flow parameters with reference to particle size and shape, *International Journal of Pharmaceutics*, 547 (2018) 133-141.
- [64] E. Emery, J. Oliver, T. Pugsley, J. Sharma, J. Zhou, Flowability of moist pharmaceutical powders, *Powder Technology*, 189 (2009) 409-415.
- [65] J. Wong, P.C.L. Kwok, H.-K. Chan, Electrostatics in pharmaceutical solids, *Chemical Engineering Science*, 125 (2015) 225-237.
- [66] K. Thalberg, D. Lindholm, A. Axelsson, Comparison of different flowability tests for powders for inhalation, *Powder Technology*, 146 (2004) 206-213.
- [67] EDQM, 2.9.34. Bulk Density and Tapped Density of Powders, in: *European Pharmacopoeia 10th Edition*, 2018, pp. 384-387.
- [68] EDQM, 2.9.36. Powder Flow, in: *European Pharmacopoeia 10th Edition*, 2018, pp. 387-390.
- [69] S. Koynov, B. Glasser, F. Muzzio, Comparison of three rotational shear cell testers: Powder flowability and bulk density, *Powder Technology*, 283 (2015) 103-112.
- [70] S. Palzer, Agglomeration of pharmaceutical, detergent, chemical and food powders—similarities and differences of materials and processes, *Powder Technology*, 206 (2011) 2-17.
- [71] F. Podczek, The influence of particle size distribution and surface roughness of carrier particles on the in vitro properties of dry powder inhalations, *Aerosol Science & Technology*, 31 (1999) 301-321.
- [72] Y.A. Abramov, Understanding the risk of agglomeration of polar pharmaceutical crystals, *Crystal Growth & Design*, 17 (2017) 2873-2880.
- [73] O.-R. Arndt, *Einfluss von Trockenbindemitteln auf die Granulierung und Tablettierung*, Verlag Dr. Hut, Düsseldorf, 2019.
- [74] O.-R. Arndt, P. Kleinebudde, Roll compaction and tableting of high loaded metformin formulations using efficient binders, *AAPS PharmSciTech*, 19 (2018) 2068-2076.

- [75] WHO, Diabebes, <https://www.who.int/news-room/fact-sheets/detail/diabetes>, Last Accessed: 17.05.2022.
- [76] E.A. Werner, J. Bell, CCXIV.—The preparation of methylguanidine, and of $\beta\beta$ -dimethylguanidine by the interaction of dicyanodiamide, and methylammonium and dimethylammonium chlorides respectively, *Journal of the Chemical Society, Transactions*, 121 (1922) 1790-1794.
- [77] C.J. Bailey, Metformin: historical overview, *Diabetologia*, 60 (2017) 1566-1576.
- [78] WHO, WHO Model List of Essential Medicines, https://www.who.int/medicines/publications/essentialmedicines/EML_2015_FINAL_amended_NOV2015.pdf?ua=1, Last Accessed: 08.03.2022.
- [79] Metformin Hydrochloride Market 2020, <https://dataintel.com/report/metformin-hydrochloride-market/#:~:text=The%20global%20metformin%20hydrochloride%20market,of%20diabetes%20across%20the%20globe.>, Last Accessed: 17.05.2022.
- [80] C.J. Bailey, R.C. Turner, Metformin, *New England Journal of Medicine*, 334 (1996) 574-579.
- [81] C.J. Bailey, Biguanides and NIDDM, *Diabetes Care*, 15 (1992) 755-772.
- [82] Fachinformation: Metformin-ratiopharm® 500 mg/850 mg/1000 mg Filmtabletten, <https://www.ratiopharm.de/assets/products/de/label/Metformin-ratiopharm%20500%20mg850%20mg1000%20mg%20Filmtabletten%20-%202.pdf?pzn=823919>, Last Accessed: 08.03.2022.
- [83] M. Lindenberg, S. Kopp, J.B. Dressman, Classification of orally administered drugs on the World Health Organization Model list of Essential Medicines according to the biopharmaceutics classification system, *European Journal of Pharmaceutics and Biopharmaceutics*, 58 (2004) 265-278.
- [84] I. Benmessaoud, O. Koutchoukali, M. Bouhelassa, A. Nouar, S. Veessler, Solvent screening and crystal habit of metformin hydrochloride, *Journal of Crystal Growth*, 451 (2016) 42-51.
- [85] D. Clemett, K.L. Goa, Celecoxib, *Drugs*, 59 (2000) 957-980.
- [86] S.Y.K. Fong, A. Ibisogly, A. Bauer-Brandl, Solubility enhancement of BCS Class II drug by solid phospholipid dispersions: spray drying versus freeze-drying, *International journal of pharmaceutics*, 496 (2015) 382-391.
- [87] K. Wang, C.C. Sun, Direct compression tablet formulation of celecoxib enabled with a pharmaceutical solvate, *International Journal of Pharmaceutics*, 596 (2021) 120239.
- [88] A. Siew, Key considerations in capsule filling, *Pharmaceutical Technology*, 41 (2017) 30-34.
- [89] S. Paul, L.J. Taylor, B. Murphy, J. Krzyzaniak, N. Dawson, M.P. Mullarney, P. Meenan, C.C. Sun, Mechanism and kinetics of punch sticking of pharmaceuticals, *Journal of Pharmaceutical Sciences*, 106 (2017) 151-158.

2. Aim of the thesis

The aim of this work is to use a simple particle engineering platform to improve the flowability and micromeritic properties of an API or excipient for which a direct compression into tablets with sufficient strength and uniformity has not yet been described in literature.

Metformin hydrochloride was identified as a suitable candidate as it is an API with poor flowability and a strong tendency towards storage agglomeration. Its direct compression has not been realized in literature. In a recent dissertation from the institute (Arndt, 2018), a dry granulation method for metformin hydrochloride was developed as a more cost-effective alternative to the commonly used wet granulation. The aim of this work is to remove the need for an intermediary granulation step in the tableting process by enabling the direct compression of metformin hydrochloride, thereby reducing production time and costs.

A suitable particle engineering platform first needs to be identified for the highly water-soluble metformin hydrochloride to produce particles with a high drug load and improved flowability and micromeritic properties while reducing the storage agglomeration tendencies.

Since no simple spherical crystallization technique has been described in literature for metformin hydrochloride, an apparatus needed to be designed and built which can be used for different spherical crystallization techniques. A spherical crystallization technique should then be developed for metformin hydrochloride and the effect of different formulation compositions and operating conditions of the crystallizer studied. The data should also provide further insights into the mechanism of QESD crystallizations. The suitability of the produced powder for direct compression at industrial tableting speed should then be evaluated.

The final objective is to transfer the established batch crystallization method into a continuous one and thereby demonstrate that continuous manufacturing is advantageous as an increase batch size and a better control of the system parameters can be achieved. For this, the initially developed batch crystallizer should be modified to allow for the continuous spherical crystallization of metformin hydrochloride without a loss in product quality.

3. Results and Discussion

3.1 Improving flowability and reducing storage agglomeration of metformin hydrochloride through QESD crystallization

This publication describes the initial development of the QESD crystallization platform and the crystallization formulation for metformin hydrochloride. At first, the effect of different QESD stabilizers and the concentration of the API solution on the agglomerate properties, such as particle size distribution and flowability, was analyzed. It was further evaluated if the novel crystallization technique for this API changed its crystallinity and whether the agglomeration tendency of the newly created MF containing powder was lower compared to the unprocessed raw material. Then, the reproducibility of batch production was determined to allow for a better study of the influence of certain process parameters of the crystallizer, such as stirring speed, temperature and volume of API solution added to the crystallizer, on critical agglomerate attributes.

Improving flowability and reducing storage agglomeration of metformin hydrochloride through QESD crystallization

Jerome Hansen and Peter Kleinebudde

Heinrich-Heine-Universitaet Duesseldorf, Institute of Pharmaceutics and Biopharmaceutics,
UniversitaetsstraÙe 1, 40225 Duesseldorf, Germany

European Journal of Pharmaceutics and Biopharmaceutics 159 (2021) 170-176

© 2021 Elsevier B.V. All rights reserved.

Article available online at:

<https://doi.org/10.1016/j.ejpb.2021.01.004>

3.2 Enabling the direct compression of metformin hydrochloride through QESD crystallization

This publication was a continuation of the work describes in the previous one. The aim was to see whether the newly created metformin hydrochloride containing powder not only had adequate flowability properties for direct compression but if tablets with a high drug load and sufficient strength could actually be produced. The mass uniformity and disintegration time of these tablets were evaluated according to the European Pharmacopeia. The work further analyzed the influence of punch speed and the use of pre-compression to increase the strength of tablets pressed from porous material to overcome deaeration issues. Finally, stabilizers used in literature for different QESD crystallizations were critically evaluated regarding their influence on the strength of tablets produced from the obtained agglomerates.

Enabling the direct compression of metformin hydrochloride through QESD crystallization

Jerome Hansen and Peter Kleinebudde

Heinrich-Heine-Universitaet Duesseldorf, Institute of Pharmaceutics and Biopharmaceutics,
UniversitaetsstraÙe 1, 40225 Duesseldorf, Germany

International Journal of Pharmaceutics 605 (2021) 120796

© 2021 Elsevier B.V. All rights reserved.

Article available online at:

<https://doi.org/10.1016/j.ijpharm.2021.120796>

3.3 Towards a better understanding of the role of stabilizers in QESD crystallizations

This work focused on gaining further understanding on the mechanism of agglomerate formation during a QESD crystallization. Furthermore, the actual role of the QESD stabilizer should be clarified as well as the importance of a strong interaction between the API and stabilizer. A new viscosity-based screening techniques was developed for this publication to minimize the effect of the different nominal viscosities of QESD stabilizers. Two APIs, metformin hydrochloride with a high solubility in water and celecoxib with a low solubility in water, were used as model drugs to study the effect of the polymeric stabilizer used for the QESD crystallization. In particular, the effect of the substitution type and molecular weight of hypromellose on the agglomerate properties was studied. Furthermore, the suitability of other polymeric stabilizers was evaluated as well as the influence of the location of the stabilizer (inner or outer phase of the transient emulsion). Lastly, a transfer of the originally developed formulation using a low molecular weight hypromellose to other APIs with similar solubilities was evaluated.

Towards a better understanding of the role of stabilizers in QESD crystallizations

Jerome Hansen and Peter Kleinebudde

Heinrich-Heine-Universität Duesseldorf, Institute of Pharmaceutics and Biopharmaceutics,
Universitätsstraße 1, 40225 Duesseldorf, Germany

Pharmaceutical Research (2022) published online

© 2022 Springer Nature All rights reserved.

Article available online at:

<https://doi.org/10.1007/s11095-022-03212-2>

3.4 Increasing the batch size of a QESD crystallization by using a MSMPR crystallizer

As was shown in Section 3.1, the particle size of QESD agglomerates is affected by the solvent fraction of the mother liquor. An increased amount of API solution added to the crystallizer during batch production also increases the solvent fraction which leads to a reduction in the particle size of newly created agglomerates. This is due to the reduced rate of counter-diffusion of the solvent and antisolvent. A possibility to circumvent this issue is the use of a continuous crystallizer, as the mother liquor can be continuously replaced by fresh antisolvent, thereby limiting its solvent fraction. This section focused on the conversion of the previously developed batch QESD crystallizer into a continuously operated mixed-suspension mixed-product removal one. The aim of the work was to see whether the solvent fraction could be controlled to maintain a constant particle size distribution during crystallization independent of the batch size. Furthermore, simple models were to be developed to allow for the prediction of key process parameters such as the mean residence time and solvent fraction. These were to be verified using tracer measurements.

Increasing the batch size of a QESD crystallization by using a MSMPR crystallizer

Jerome Hansen and Peter Kleinebudde

Heinrich-Heine-Universitaet Duesseldorf, Institute of Pharmaceutics and Biopharmaceutics,
UniversitaetsstraÙe 1, 40225 Duesseldorf, Germany

Pharmaceutics 14 (2022) 1227

© 2022 Multidisciplinary Digital Publishing Institute All rights reserved.

Article available online at:

<https://doi.org/10.3390/pharmaceutics14061227>

4. Conclusion

Metformin hydrochloride is a highly water-soluble drug used in the treatment of non-insulin-dependent diabetes mellitus. It is available on the market in the form of highly drug loaded tablets with a dosage of 500-1000 mg. Due to the poor flowability and agglomeration tendency under storage a direct compression into tablets was not yet described in literature. A wet or dry granulation step is required to improve the flowability of the bulk material. Intermediary production steps however lead to an increased production time, cost and energy consumption. The aim of this work was therefore to create a simple particle engineering technique for metformin hydrochloride to enable its direct compression into tablets with a high drug load and adequate strength, disintegration behavior and mass uniformity at production speeds.

The QESD crystallization technique was used as a particle engineering platform for MF. Initially, a batch crystallizer and a crystallization formulation had to be developed for the highly water-soluble API. Hypromellose was identified as a suitable stabilizer for the transient emulsion of the aqueous API solution in acetone. While a regular antisolvent crystallization of MF in acetone yielded irregular particles with poor flowability and a tendency to agglomerate when stored, the QESD crystallization technique could be used to create hollow, spherical agglomerates of the API. The agglomerates had good flowability and showed a reduced tendency towards storage agglomeration while maintaining their crystallinity. Additional non-ionic surfactants could be added to the system to further stabilize the transient emulsion and thereby improve agglomerate properties. However, the surfactants can have a negative impact on the tablet strength. Changing the operating conditions confirmed data from other publications regarding, e.g. the impact of stirring speed, crystallization temperature and solvent fraction in the mother liquor on agglomerate properties, in particular regarding the agglomerate size. The developed setup could be used to produce consecutive batches while maintaining specific quality attributes. Therefore, more material could be crystallized for larger tableting or stability studies.

Tableting the QESD MF revealed that judging the suitability of a QESD powder for direct compression cannot be performed by solely determining product attributes such as flowability and particle size distribution. At first, deaeration issues were discovered due to the porous nature of the hollow particles which led to capping during tableting. This issue could be overcome by either reducing the punch speed during tableting or by implementing a precompression cycle, as it is often done when using rotary tablet presses. Furthermore, it could be shown that tablets with a drug load of > 90 % could be compressed into tablets at simulated production speeds of up to 150,000 tablets per hour with sufficient strength and mass uniformity. It could also be shown that non-ionic surfactants used to stabilize the transient emulsion during crystallization can reduce the tablet strength. This is due to their lubricating effect when absorbed to the surface of the agglomerates. Data provided by this study therefore demonstrated that some QESD crystallization formulations described in literature might not be suitable for a compression of the material into tablets. The effect of the emulsifiers on tablet strength had not yet been described in literature and tableting data is often not provided by the authors.

To gain a better understanding for the role of the stabilizer during QESD crystallization, a novel viscosity-based screening technique was developed. A multitude of different polymeric QESD stabilizers can be found in literature, however their comparison to one another had usually been done at a defined concentration. Since these polymers often differ in their nominal viscosity, the resulting droplet size, diffusion rate, crystal growth rates, etc. would therefore also be affected. Comparing different polymeric stabilizers at a set viscosity showed that the location of the stabilizer, whether it is dissolved in the inner or outer phase of the emulsion, has the largest impact on the success of a QESD crystallization. Furthermore, it could be shown for MF that the substitution type and molecular weight of hypromellose can have a significant impact on the agglomerate properties and whether hollow, spherical particles can even be obtained. In contrast to previously published data concerning the suitability of hypromellose and polyvinylpyrrolidone as QESD stabilizers, spherical agglomerates of celecoxib

could in fact be crystallized when adjusting their concentration according to the viscosity-based screening technique.

For the final part of this work regarding the QESD crystallization of MF the initially developed batch crystallizer was converted into a continuously operated one, a mixed-suspension mixed-product removal crystallizer in particular. The primary motivation behind this work was to increase the batch size of a single run at lab scale, as it was previously limited in the batch production by the solvent fraction of the mother liquor during crystallization. The development of a MSMPR crystallizer for QESD crystallizations was described in detail as several challenges, such as the slurry transfer of the fragile agglomerates and the encrustation of the walls of the crystallizer due to the polymeric stabilizer, had not yet been described in literature. The work showed, that the MSMPR crystallizer could be used to increase the batch size while maintaining the particle size distribution of the agglomerates by reducing the solvent fraction of the mother liquor. Furthermore, the influence of process parameters specific to a continuous crystallizer such as mean residence time and average solvent fraction were analyzed. Lastly, measurements of the mean residence time using tracer experiments revealed a first order elimination kinetic from the crystallizer. This allowed for the correct prediction of mean residence times and the solvent fraction throughout the crystallization process which were verified using further tracer measurements. The MSMPR crystallizer could however not be run in a truly continuous manner, as only a single peristaltic pump was available at the time. This meant that the flow rate of fresh antisolvent added to the crystallizer was equal to that of the slurry removal at the outlet (Fig. 4), which led to an increased volume over time.

Overall, the QESD crystallization technique could be used as a particle engineering approach to produce hollow, spherical agglomerates of various APIs. QESD MF in particular showed improved flowability and micromeritic properties as well as reduced agglomeration tendencies. The free-flowing powder could be directly compressed into highly drug loaded tablets with sufficient strength, disintegration time and mass uniformity. The development of a novel screening technique for QESD stabilizers allowed for the gain of further insights into the role

of these stabilizers during crystallization. Lastly, the initially developed batch crystallizer was successfully converted into a continuously operated mixed-suspension mixed-product removal crystallizer to increase the batch size during lab scale production.

During the course of this work other manuscripts describing QESD crystallizations have been published, however these are not in direct conflict with the findings presented here. A large portion of the published manuscripts comes from the members of the working group of Prof. Changquan Calvin Sun. Their work has also focused on the role of the interaction between the API and stabilizer. Furthermore, they identified other improved product properties brought on through the QESD process [1], reasons for the improved tableability of QESD material [2] and the development of QESD co-crystals to improve drug dissolution [3]. Other work published during this time has described, e.g. the use of inkjet printing nozzles to improve the control of the transient emulsion droplet size [4] and compared product attributed when crystallizing the same drug using different spherical crystallization techniques [5].

References

- [1] H. Chen, S. Paul, H. Xu, K. Wang, M.K. Mahanthappa, C.C. Sun, Reduction of punch-sticking propensity of celecoxib by spherical crystallization via polymer assisted quasi-emulsion solvent diffusion, *Molecular Pharmaceutics*, 17 (2020) 1387-1396.
- [2] Chen, C. Wang, H. Kang, B. Zhi, C.L. Haynes, A. Aburub, C.C. Sun, Microstructures and pharmaceutical properties of ferulic acid agglomerates prepared by different spherical crystallization methods, *International Journal of Pharmaceutics*, 574 (2020) 118914.
- [3] H. Chen, H. Xu, C. Wang, H. Kang, C.L. Haynes, M.K. Mahanthappa, C.C. Sun, Novel quasi-emulsion solvent diffusion-based spherical cocrystallization strategy for simultaneously improving the manufacturability and dissolution of indomethacin, *Crystal Growth & Design*, 20 (2020) 6752-6762.
- [4] K. Kadota, Y. Shirakawa, Particle preparation and morphology control with mutual diffusion across liquid-liquid interfaces, *KONA Powder and Particle Journal*, 38 (2021) 2021006.
- [5] K. Chen, B. Hou, H. Wu, X. Huang, F. Li, Y. Xiao, J. Li, Y. Bao, H. Hao, Hollow and solid spherical azithromycin particles prepared by different spherical crystallization technologies for direct tableting, *Processes*, 7 (2019) 276.

5. Summary and Outlook

This work demonstrated that QESD crystallizations can be used as a platform of particle engineering to enable the direct compression of APIs, such as MF. QESD crystallizations can not only increase the flowability of an API or excipient but also improve other product attributes such as tabletability and storage agglomeration. This work also deepened the published knowledge on the mechanism of QESD crystallizations and demonstrated that continuous crystallizers can be used at the lab scale to increase production capacity. The method is however not without fault, as finding a suitable crystallization formulation still mainly relies on a trial-and-error approach. Furthermore, the use of certain QESD stabilizers, specifically non-ionic surfactants, can lead to a reduced tablet strength. The porous material obtained through QESD crystallizations can cause deaeration issues during tableting.

One remaining issue is the low bulk density of the porous agglomerates which initially led to deaeration issues during tableting and required a large filling volume of the die during tableting. Some trials had been done which attempted to increase the bulk density by increasing the concentration of the MF solution, however these failed due to the blockage of the tubing coming from the syringe pump. Ongoing work should focus on creating an improved dosing setup, implementing a heated tube or an automated washing cycle of the tube tip, to avoid this issue. Furthermore, running the MSMPR crystallizer with two peristaltic pumps would allow for truly continuous operation and simplified prediction of the mean residence time and solvent fraction during crystallization. A further improvement would be the implementation of PAT tools to allow for a closer monitoring of the system. An implementation of the Parsum probe was attempted, however it failed as the flow rates in the system were too low for the loading of the sensor. Using FBRM would allow for the continuous monitoring of agglomerate size and count within the crystallizer. Lastly, the development of a continuous filtration and drying system would allow for easy continuous operation and could also improve the yield, as some of the material would agglomerate into large clumps when dried on the stainless-steel sieves without agitation.

6. Danksagung

Ich möchte mich zuallererst bei meinem Doktorvater, Herrn Prof. Dr. Dr. h.c. Peter Kleinebudde, für die Aufnahme in seinen Arbeitskreis und der außerordentlichen Führung meiner Promotionsarbeit danken. Ihre Tür war stets für mich geöffnet und Sie nahmen sich immer die Zeit, Probleme und Hypothesen ausführlich zu besprechen, selbst wenn Ihr Arbeitstag bereits prall gefüllt war. Ich bedanke mich für Ihre ehrliche und offene Art im Umgang mit wissenschaftlichen Daten und Diskussionen und ihrer konstruktiven Kritik und Lenkung meiner Arbeit. Ich bedanke mich ebenfalls für ihre mehrfache Ermahnung, dass man die Form von Partikeln als „sphärisch“ und nicht „rund“ bezeichnet. Ich bedanke mich ebenfalls für die Weinverkostung bei Ihnen im Garten und die schönen Abende bei Ihren Geburtstagsfeiern.

Ich danke meinem Mentor, Herrn Prof. Jörg Breitzkreutz, für die Übernahme des Koreferats und den kritischen Rückfragen und kreativen Lösungsansätzen in Fokusgruppen und im Anschluss an Präsentationen. Sie haben Probleme immer aus einem anderen Blickwinkel betrachtet und konnten so wertvolle Ideen miteinbringen, die ich so sonst nicht beachtet hätte.

Dr. Klaus Knop, ich danke dir für deine vielen praktischen Ratschläge und Korrekturen verschiedener Publikationen und Kongressbeiträge. Ich habe deine ehrliche Beurteilung von Daten und Hypothesen immer sehr geschätzt und von dir gelernt, dass man Ergebnisse am besten immer kurz und präzise darstellt. Ich wünsche dir alles Gute für deinen wohlverdienten Ruhestand, du wirst dem Institut aber sehr fehlen.

Ich möchte mich ebenfalls bei Stefan Stich und der Feinmechanik der HHU für die zahlreichen Anfertigungen und Optimierungen meiner Apparatur bedanken. Stefan, dir danke ich besonders für deine kreativen Beiträge zu meiner Arbeit und dass du Aufträge von mir immer schnell aber sehr gründlich durchgeführt hast.

Meinen beiden WPP Gruppen, Elisabeth Krotov und Vanessa Splett sowie Janine Klode und Franziska Glatz, möchte ich für ihren Fleiß und gute Arbeit danken, die mir wirklich sehr geholfen hat.

Sebastian „Ronny“ Pohl, ich bedanke mich bei dir für die unzähligen Wein-Abende, die feuchtfröhlichen Abendessen im Schweine-Janes, für deinen ausgesprochenen guten Humor und dein außerordentlich lautes und markantes Gelächter, welches mich immer aufheitern kann.

Ich danke Hellen Windolf und Rebecca Chamberlain für die Aufnahme in ihr Büro am Anfang meiner Arbeit und für die wirklich witzige Zeit in unserem Büro auf 00, für die kleinen Schabernacke im Alltag (seitdem Rebecca ihren PC immer zu sperren weiß), für die schönen Erinnerungen bei der Konferenz in Bologna und für den Vorfall mit der Paprika...

Ich bedanke mich ebenfalls bei meinen späteren Bürokollegen, Anja Göbel, Katharina Kiricenko und Martin Lück, für die amüsante Zeit am Arbeitsplatz, eure Ablenkungen waren immer willkommen, um mir den Arbeitsalltag zu versüßen. Anja danke ich besonders für die zahlreichen witzigen Telefonate bei denen ich zuhören durfte, Katja danke ich für die Einführung in das kulinarische Erlebnis der „Jelly-Shots“ und Martin für seine rheinische Mentalität und Lebensart.

Dr. Annika Wilms danke ich für die schöne gemeinsame Zeit am Institut, für unsere gemeinsame Liebe für Schlagermusik und für die tolle gemeinsame Reise zur Konferenz nach Freiburg. Dr. Vincent Lenhart und Dr. Raphael Wiedey danke ich für eure Unterstützung am Anfang meiner Promotion, eure Türen standen immer offen, wenn ich Fragen oder Probleme hatte. Von Vincent habe ich auch gelernt wie man Arbeit und (Feierabend-)Spaß am Institut kombiniert. Hanna „Plappi“ Plappert, ich danke dir für die unzähligen Lachanfänge, die wir zusammen hatten, für deine Liebe zu Insekten und Spinnen und die zahlreichen Trash-TV Abende, meine Couch steht dir immer zur Verfügung. Jhinuk Rahman-Yildir, dir danke ich für deinen ausgezeichneten Geschmack für amerikanische Filme und dass du sie auch alle zitieren kannst. Denk daran: If something goes wrong, it's „no bueno“!

Ein besonderer Dank geht auch an die „Institut BoYz“ für die Fahrten nach Zeeland und in die Eifel, für die zahlreichen Altstadt-Abende und für die Männer-Frühstücke im Königreich. Mit euch könnte man tatsächlich die Welt retten (wenn wir vorher nicht im Shooters versacken...).

Ich möchte mich ebenfalls bei allen anderen nicht genannten Mitgliedern des Instituts herzlichst bedanken, für die unglaublich schöne Zeit, für die gemeinsamen Diskussionen, Karnevals-Feiern, Altstadt-Abende, Kaffeepausen, Mensa-Gänge, Konferenzbesuche, Exkursionen und Seminare. Ich werde euch alle sehr vermissen!

Zuletzt möchte ich mich noch bei meiner Familie und Sonja bedanken, für die grenzenlose Unterstützung während meiner Arbeit.

7. Eidesstattliche Erklärung

Ich versichere an Eides Statt, dass die Dissertation von mir selbständig und ohne unzulässige fremde Hilfe unter Beachtung der „Grundsätze zur Sicherung guter wissenschaftlicher Praxis an der Heinrich-Heine-Universität Düsseldorf“ erstellt worden ist.

Jerome Hansen